

FPBS 52103 R

FLAME PROOF ROTARY SWITCH



Mechanical Data

- Material : Aluminium LM6
- Weight : 3.8 Kg (Approx.,)
- IP Protection : IP 65
- Finish : Anti corrosive Epoxy Powder coated
- Cable Entry : 2 x (0.75"ET / 0.5" NPT / BSP / M20)
- Gasket : Neoprene
- Hardware : Stainless Steel

Electrical Data

- Switch Rating: 4A DP to 16 A DP (240 V AC)
- Wiring : PVC insulated 1.5 sq.mm stranded copper
- Terminals : Refer the chart below
- Earthing : External : 2 Nos - M6
Internal : 1 No - M5

Terminals Chart

Max no of clipon terminals				Max no of control components
2.5 mm ²	4 mm ²	10 mm ²	16 mm ²	
8	8	-	-	01

Description

Explosion proof, rotary on-off switches are basically meant for switching lighting circuits. These high making and breaking capacity switches are placed in a separate enclosure and pre-wired to terminals placed in an integral chamber. The terminal chamber is gasketed to provide a high degree of weather protection.

GA Drawing

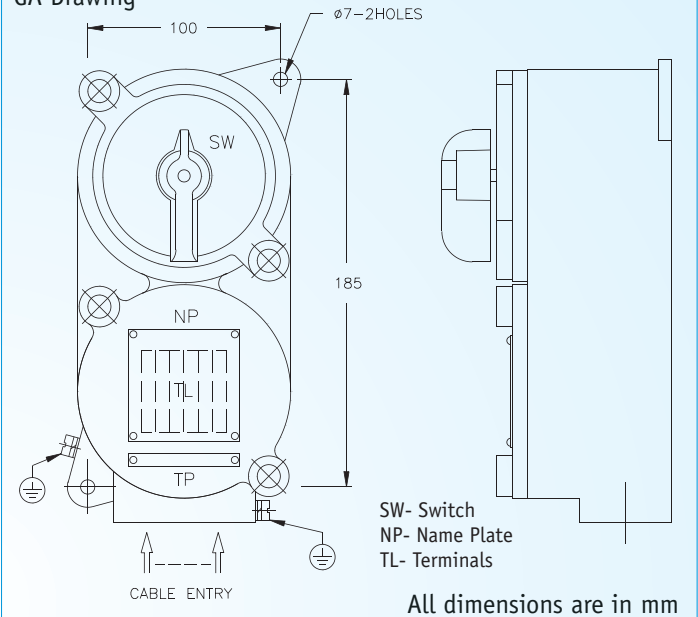

Type of protection	Flame Proof - Exd
Area Classification	Zone 1 & 2
Gas Groups	Group I, II A ,II B
Apparatus Standard	IS - 2148 / 81
CMRI Certificate No.	V / 1 / 1 / 994
Approvals	CCE,BIS

1

2

3

4

DO NOT SCALE

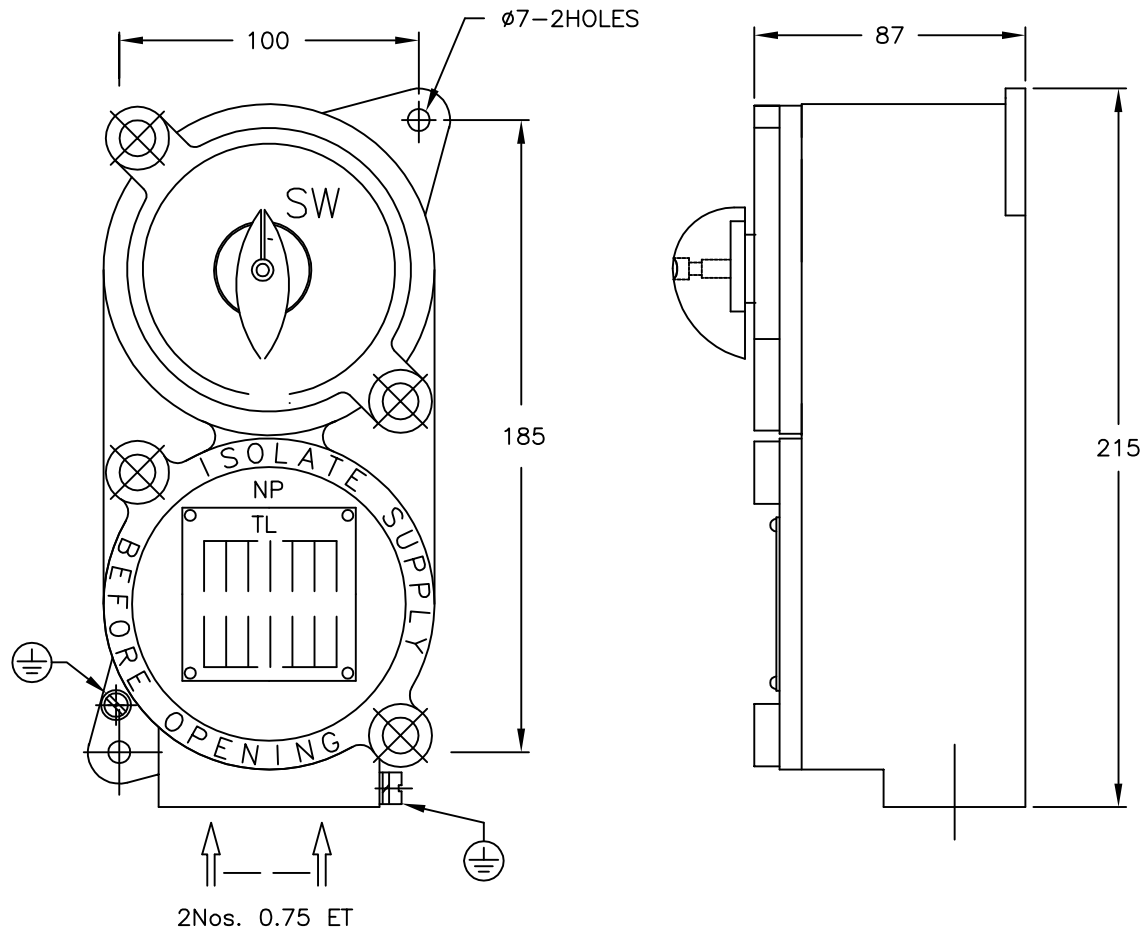
**NOTES:**

- SW - 16A, DP 24V DC ON/OFF ROTARY SWITCH
- TL - 6Nos. 2.5SQ.MM TERMINAL- ELMEX MAKE
- NP - NAME & WARNING PLATE (SS)
- TP - TAG PLATE (PERSPEX) (CUSTOMER TO FURNISH TAG DETAIL IF ANY)
- EARTHING - 2Nos. EXTERNAL & 1No. INTERNAL
- HARDWARE - SS304

WIRING DIAGRAM

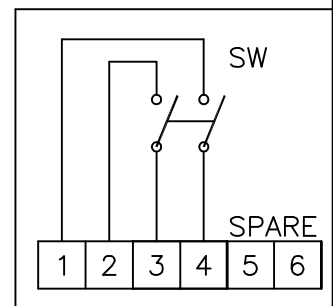

ALL DIMENSIONS ARE IN MM.

CUSTOMER:	TITLE : EXPLOSIONPROOF ISOLATOR		
CONSULTANT :	CAT No. : FPBS-52103R		
PROJECT :	CLASSIFICATION : Exd IIB IP65 ZONE 1&2 T6		
P.O. No.:	WT.:2.5KGS.MATL.: AL. (APPROX.) LM-6	ITEM No.: QTY.:	
FINISH : EPOXY POWDER COATED LIGHT GREY (SHADE-631 OF IS:5)	TOLERANCE: ±5mm. SCALE N.T.S	FOR INFORMATION ONLY	
CMRI : V/1/1/994 DT:26.12.89	IS: 13346/04 (IEC:60079-0/00)		DATE
CCE : R1(1)136/BALIGA/12-XVIII, DT:24.12.04	IS: 2148/04 (IEC:60079-1/01)	REV-1	SHEET 1 OF 1
BIS : CM/L-0364341	IS: 12063/87 (IEC:60529/89)	REV-2	
Baliga Lighting Equipments Private Limited, KOVILAMBAKKAM, CHENNAI-600117, INDIA.		DRN. S.S 13.03.09	DRG. No. REV
		CHKD.	QE52103R01 0
		APPD.	

1

2

3

4

केन्द्रीय खनन एवं ईंधन अनुसंधान संस्थान

(वैज्ञानिक तथा औद्योगिक अनुसंधान परिषद)
बरवा रोड, धनबाद - 826 001, झारखण्ड, भारत



ADDITIONAL FIRST COPY

Central Institute of Mining and Fuel Research

Formerly : Central Mining Research Institute
(Council of Scientific & Industrial Research)
BARWA ROAD, DHANBAD-826 001, JHARKHAND, INDIA

REGISTERED POST/COURIER SERVICE

No. CIMFR/TC/SR/H334
I.D. No. 756/07

Dated: 28th July, 2008
CODE NO.FLP/204ZV/08

To,
BALIGA LIGHTING EQUIPMENTS PRIVATE LIMITED,
63A, C.P. RAMASWAMY ROAD,
ALWARPET,
CHENNAI-600 018

Sub: Supplementary Testing for **REVALIDATION** as per IS: 2148- 2004 (IEC 60079-1/2001) of your **Flameproof & Weatherproof Control Station (IP-65)** as designated by Cat. No.: **FPBS-52503**, in cast aluminium alloy LM-6 construction for use in Gas Groups: IIA & IIB and Zone 1 & 2 atmospheres only.

- Report on (REVALIDATION)

Your Ref. No. CMRI/6/242/IIB

Dated: 12/12/2007

Dear Sir,

Please find enclosed the **Supplementary Test Report** for **REVALIDATION** of the above sample as per IS: 2148-2004.

The above apparatus was earlier certified as per IS: 2148-1981 vide CMRI Certificate No. CMRI/TC/H564, Dated: 17/04/1997 mentioned in the schedule of this report.

Charges of **Rs. 13,754/- (Rupees Thirteen thousand Seven hundred Fifty four)** only including applicable service charges involved towards the testing/issuing the schedule have been adjusted against the advance deposit made by you.

Kindly arrange to collect the sample within 90 days from the date of receipt of this letter failing which CIMFR would dispose off the sample by public auction without any further NOTICE to you.

Kindly acknowledge receipt.

Thanking you,

Yours faithfully,

(G. M. PRASAD)

HEAD OF THE DEPARTMENT
TESTING CELL

Encl.: As above
Supplementary Report for Revalidation in Triplicate
Copy to: 1. Head, Flame & Explosion Lab.
2. Bill Section.

1 of 8

फोन-निदेशक Director
Ph.: 0091-326-2202326/2203043

पी० ए० एक्स PAX
Ph.: 0091-326-2203010/2203070/2203090/2205045/2209041

फैक्स FAX
0091-326-2201442/2202429/2204339/2203156

e-mail : dcmrips@yahoo.co.in, dcmri@csir.res.in • Website : www.cmriindia.nic.in

कार्यालय के दिन : सोमवार से शुक्रवार तक Working days : Monday to Friday